

LARGE PARCEL & FREIGHT X-RAY IMAGING SYSTEM

XRC 100-100



This x-ray baggage scanner facilitates the operators use thanks to the various image processing functions, hazard alarm, advanced computer technology and the best in class software. It provides exceptional ease in detecting threats such as cutting tools, explosives narcotics and minimizes the error rate. **XRC 100-100** offers unique image quality by showing the scanned organic, inorganic and mixed items in different colors thanks to its multi-diode structure and quality in imaging of scanned objects which is designed with the latest technology system to scan medium and large bags and packages.

Institutions ensure that packages are inspected in places where inspection is required, such as high traffic checkpoints, city transportation (metro, ferry, train stations), customs border crossings, prisons, and courier depots like international logistics companies, goods acceptance points and etc.

TECHNICAL DATA XRC 100-100

PHYSICAL PROPERTIES

Tunnel Size	: 1000 mm x 1000 mm
(W x H)	: 39,37 in x 39,37 in
Dimensions	: 3550 mm x 1930 mm x 1410 mm
(L x H x W)	: 139,76 in x 75,98 in x 55,51 in
Approx. Weight Unpacked	: ~1150 kg (2535 lbs.)
Conveyor Height	: 790 mm (31,10 in)
Conveyor Load Capacity	: 200 kg (441 lbs.) Evenly Distributed
System Power	: 110/220V AC ± 10% 50/60 Hz, 8A/4A
Conveyor Speed	: 0,20 m/sec. Forward or Reverse

X-RAY GENERATOR & IMAGE PERFORMANCE

Steel Penetration ¹	: 37 mm guaranteed; 39 mm typical
Wire Resolution ¹	: 38 AWG guaranteed; 40 AWG typical
Anode Voltage	: 180kV, operating at 160kV
Tube Current	: 1,0 mA
Beam Direction	: Vertically upward
Article Separation	: Low Z, Medium Z, High Z to 0,5 Z Accuracy Organic, InOrganic, Metallic
Cooling	: Oil and forced air cooling

COMPUTER SPECIFICATIONS

Processor	: Intel® Core™ i5 (or superior)
Monitor	: 21,5" Flat LCD (or superior)
Memory	: 4 GB RAM (or superior)
Video Card	: 2 GB (or superior)
Hard Drive	: 1 TB (or superior)
USB Port	: 6 port (or superior)
Operating System	: Linux

OPERATING ENVIRONMENT

Storage / Operating Temperature	: -20°C to 50°C / 0°C to 40°C (-4°F to 122°F / 32°F to 104°F)
Relative Humidity	: 0% to 95% non-condensing
Duty Cycle 100% (24 Hours), No warm-up required	

HEALTH AND SAFETY

All X-Ray Center Ltd products meet all applicable international health and safety regulations.
 US FDA Federal Standard 21CFR 1020.40
 Health and Safety at Work Act 1974-compliant 6 : Available
 Film Safety : ISO 1600 / 33 DIN
 CE Compliance : Certified
 FCC & IEC Compatibility : Available
 IP 20 Safety : Certified
 Maximum level of radiation the exterior panels come in contact with is 0.1 mR/hour

OPTIONAL FEATURES

Barcode Reader System
 External Camera Archiving
 Remote Viewing Station
 Recheck Station
 Network Supervisory System (NSS)
 Remote Access Connection
 Smart Card Login

OPTIONAL ACCESSORIES

External UPS (For system)
 Operator Console (Open-Closed/Adjustable/I-stand)
 21,5"- 27" Flat Monitor
 Input / Output Rollers
 Test Kit (STP/ASTM)
 Protective Cover
 Search Table
 Tray Return System (Motorized/Gravity)
 Inclined Conveyor
 Ultrasonic Rat Repellent
 Radiation Meter

STANDARD IMAGE PROCESSING FEATURES

Perfect View (Detail Enhancement) (PV)
 Edge Enhancement (EE)
 Pseudo Color (PS)
 Organic Materials (OM)
 Inorganic Materials (IM)
 Black & White (B/W)
 Inverse Colors (IN)
 High Penetration (HP)
 Variable Edge Enhancement (+E -E)
 Variable Density (+D -D)
 Variable Gamma (+G -G)
 Variable Color Separation (+C -C)
 Zoom (64x)
 Sniper Zoom
 Recall Previous Images
 Manual/Automatic Archive
 Annotated Archive
 Multi Energy Viewer (4 - 6 Color)
 Atomic Number Display (Z Value)

STANDARD FEATURES

Programmable Function Keys
 Parcel Counter
 Date and Time Display
 Virtual Threat Image Projection (TIP)
 Organic/Inorganic Threat Alarm
 Operator Training Program (OTP)
 UPS (For Computer Supply)
 Multi Languages
 Self Diagnosis
 Generator Timer
 Automatic Stop Conveyor
 Bi-Directional Scanning
 Emergency Stop Buttons

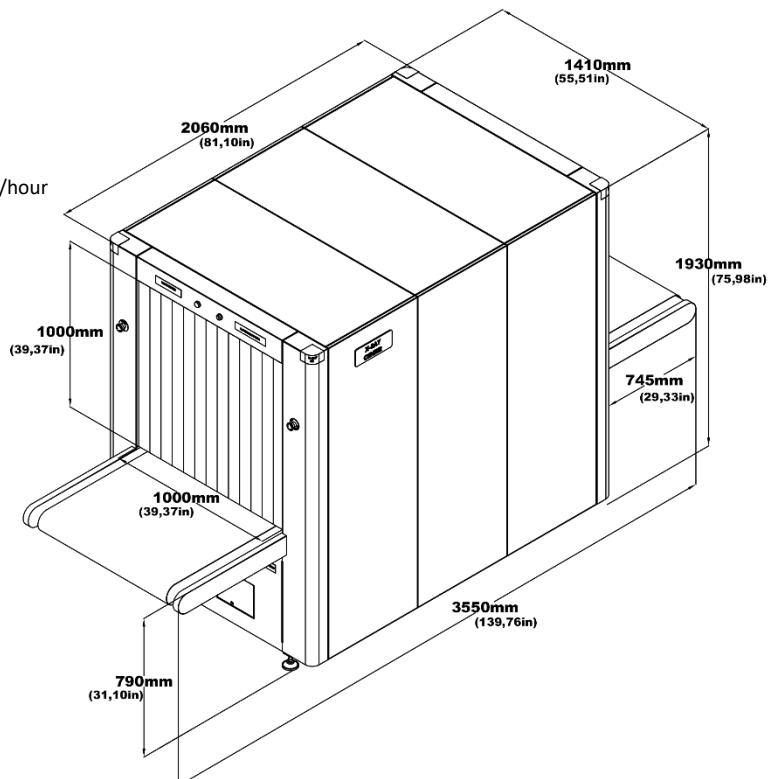

¹As tested on X-Ray Center Ltd. test piece. Conveyor speed is 0.20 m/sec.
 Due to continuous product development, X-Ray Center reserves the right to change specifications without notice.

