

LARGE PARCEL & FREIGHT X-RAY IMAGING SYSTEM

XRC 90-75



The **XRC 90-75** x-ray machine, which has a low conveyor unit. Thanks to this unit, heavy loads can be easily and conveniently placed. It facilitates the operators use thanks to the various image processing functions, hazard alarm, advanced computer technology and the best in class software. It provides exceptional ease in detecting threats such as cutting tools, explosives narcotics and minimizes the error rate.

Thanks to its multi-diode structure and quality in imaging of scanned object, image is colored based on density and shows organic, inorganic and mixed materials in different tones.

It is an efficient and a powerful x-ray scanning device that allows inspection in at high traffic checkpoints as city transportation (metro, ferry, train stations), customs border crossings, prisons, and courier depots, like international logistics companies, goods acceptance points and etc. for scanning of medium and large bags and packages in detail.

TECHNICAL DATA XRC 90-75

PHYSICAL PROPERTIES

Tunnel Size	: 915 mm x 765mm
(W x H)	: 36,02 in x 30,12 in
Dimensions	: 2890 mm x 1630 mm x 1325 mm
(L x H x W)	: 113,78 in x 64,17 in x 52,17 in
Approx. Weight Unpacked	: ~840 kg (1852 lbs.)
Conveyor Height	: 335 mm (13,19 in)
Conveyor Load Capacity	: 200 kg (441 lbs.) Evenly Distributed
System Power	: 110/220V AC ± 10% 50/60 Hz, 8A/4A
Conveyor Speed	: 0,20 m/sec. Forward or Reverse

X-RAY GENERATOR & IMAGE PERFORMANCE

Steel Penetration ¹	: 35 mm guaranteed; 37 mm typical
Wire Resolution ¹	: 36 AWG guaranteed; 38 AWG typical
Anode Voltage	: 180kV, operating at 160kV
Tube Current	: 1,0 mA
Beam Direction	: Vertically downward
Article Separation	: Low Z, Medium Z, High Z to 0,5 Z Accuracy Organic, InOrganic, Metallic
Cooling	: Oil and forced air cooling

COMPUTER SPECIFICATIONS

Processor	: Intel® Core™ i5 (or superior)
Monitor	: 21,5" Flat LCD (or superior)
Memory	: 4 GB RAM (or superior)
Video Card	: 2 GB (or superior)
Hard Drive	: 1 TB (or superior)
USB Port	: 6 port (or superior)
Operating System	: Linux

OPERATING ENVIRONMENT

Storage / Operating Temperature	: -20°C to 50°C / 0°C to 40°C (-4°F to 122°F / 32°F to 104°F)
Relative Humidity	: 0% to 95% non-condensing
Duty Cycle 100% (24 Hours), No warm-up required	

HEALTH AND SAFETY

All X-Ray Center Ltd products meet all applicable international health and safety regulations.

US FDA Federal Standard 21CFR 1020.40

Health and Safety at Work Act 1974-compliant 6 : Available

Film Safety : ISO 1600 / 33 DIN

CE Compliance : Certified

FCC & IEC Compatibility : Available

IP 20 Safety : Certified

Maximum level of radiation the exterior panels come in contact with is 0.1 mR/hour

OPTIONAL FEATURES

- Barcode Reader System
- External Camera Archiving
- Remote Viewing Station
- Recheck Station
- Network Supervisory System (NSS)
- Remote Access Connection
- Smart Card Login

OPTIONAL ACCESSORIES

- External UPS (For system)
- Operator Console (Open-Closed/Adjustable/I-stand)
- 21,5" - 27" Flat Monitor
- Input / Output Rollers
- Test Kit (STP/ASTM)
- Protective Cover
- Search Table
- Tray Return System (Motorized/Gravity)
- Inclined Conveyor
- Ultrasonic Rat Repellent
- Radiation Meter

STANDARD IMAGE PROCESSING FEATURES

- Perfect View (Detail Enhancement) (PV)
- Edge Enhancement (EE)
- Pseudo Color (PS)
- Organic Materials (OM)
- Inorganic Materials (IM)
- Black & White (B/W)
- Inverse Colors (IN)
- High Penetration (HP)
- Variable Edge Enhancement (+E -E)
- Variable Density (+D -D)
- Variable Gamma (+G -G)
- Variable Color Separation (+C -C)
- Zoom (64x)
- Sniper Zoom
- Recall Previous Images
- Manual/Automatic Archive
- Annotated Archive
- Multi Energy Viewer (4 - 6 Color)
- Atomic Number Display (Z Value)

STANDARD FEATURES

- Programmable Function Keys
- Parcel Counter
- Date and Time Display
- Virtual Threat Image Projection (TIP)
- Organic/Inorganic Threat Alarm
- Operator Training Program (OTP)
- UPS (For Computer Supply)
- Multi Languages
- Self Diagnosis
- Generator Timer
- Automatic Stop Conveyor
- Bi-Directional Scanning
- Emergency Stop Buttons

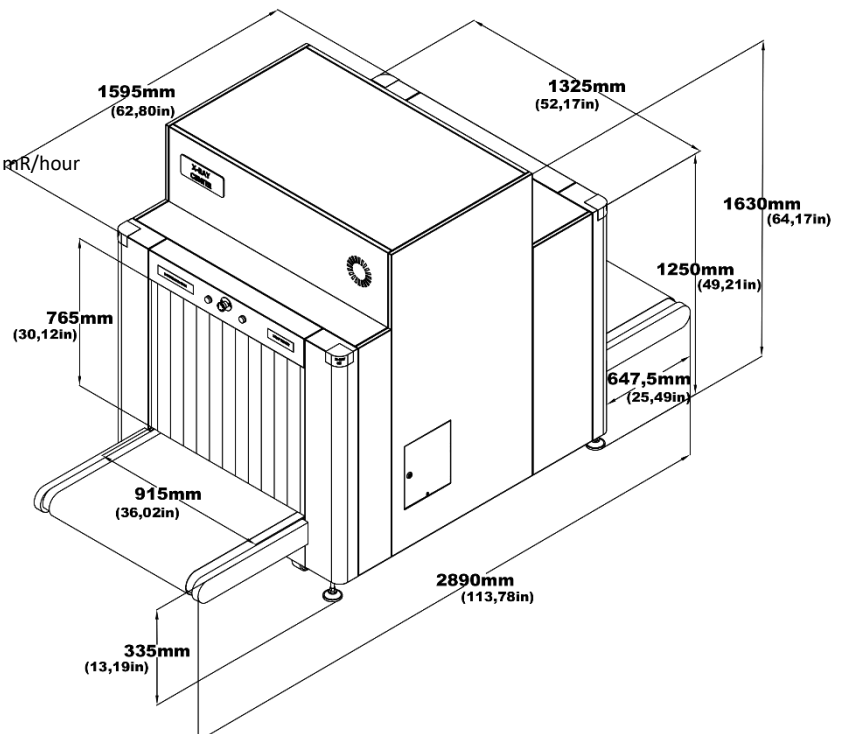

¹As tested on X-Ray Center Ltd. test piece. Conveyor speed is 0.20 m/sec.

Due to continuous product development, X-Ray Center reserves the right to change specifications without notice.

