

## SMALL PARCEL & BAGGAGE X-RAY IMAGING SYSTEM

# XRC 60-40



**XRC 60-40** is one of the XRC brand's preferred x-ray devices in terms of its dimensions and functionalities. It facilitates the operators use thanks to the various image processing functions, hazard alarm, advanced computer technology and the best in class software and it is a preferred model for locations with limited operating space. It provides exceptional ease in detecting threats such as cutting tools, explosives narcotics and minimizes the error rate. It provides unique image quality by showing the scanned organic, inorganic and mixed items in different colors thanks to its multi-diode structure and quality in imaging of scanned objects.

X-ray security scanner is designed with the latest technology system to scan small handbags, packages parcels and cabin baggage in detail. Institutions ensure that packages are inspected in places where inspection is required, such as airports, customs border gates, police departments, ministries, prisons, institutions, courts.

# TECHNICAL DATA XRC 60-40

## PHYSICAL PROPERTIES

Tunnel Size	: 610 mm x 440 mm
(W x H)	: 24,02 in x 17,32 in
Dimensions	: 2080 mm x 1370 mm x 870 mm
(L x H x W)	: 81,89 in x 53,94 in x 34,25 in
Approx. Weight Unpacked	: ~525 kg (1158 lbs.)
Conveyor Height	: 810mm (31,89 in)
Conveyor Load Capacity	: 165 kg (364 lbs.) Evenly Distributed
System Power	: 110/220V AC ± 10% 50/60 Hz, 6A/3A
Conveyor Speed	: 0,20 m/sec. Forward or Reverse

## X-RAY GENERATOR & IMAGE PERFORMANCE

Steel Penetration <sup>1</sup>	: 40 mm guaranteed; 42 mm typical
Wire Resolution <sup>1</sup>	: 38 AWG guaranteed; 40 AWG typical
Anode Voltage	: 170kV, operating at 160kV
Tube Current	: 1,0 mA
Beam Direction	: Vertically upward
Article Separation	: Low Z, Medium Z, High Z to 0,5 Z Accuracy Organic, InOrganic, Metallic
Cooling	: Oil and forced air cooling

## COMPUTER SPECIFICATIONS

Processor	: Intel® Core™ i5 (or superior)
Monitor	: 21,5" Flat LCD (or superior)
Memory	: 4 GB RAM (or superior)
Video Card	: 2 GB (or superior)
Hard Drive	: 1 TB (or superior)
USB Port	: 6 port (or superior)
Operating System	: Linux

## OPERATING ENVIRONMENT

Storage / Operating Temperature	: -20°C to 50°C / 0°C to 40°C (-4°F to 122°F / 32°F to 104°F)
Relative Humidity	: 0% to 95% non-condensing
Duty Cycle	100% (24 Hours), No warm-up required

## HEALTH AND SAFETY

All X-Ray Center Ltd products meet all applicable international health and safety regulations.

US FDA Federal Standard 21CFR 1020.40

Health and Safety at Work Act 1974-compliant 6 : Available

Film Safety : ISO 1600 / 33 DIN

CE Compliance : Certified

FCC & IEC Compatibility : Available

IP 20 Safety : Certified

Maximum level of radiation the exterior panels come in contact with is 0.1 mR/hour

## OPTIONAL FEATURES

- Barcode Reader System
- External Camera Archiving
- Remote Viewing Station
- Recheck Station
- Network Supervisory System (NSS)
- Remote Access Connection
- Smart Card Login

## OPTIONAL ACCESSORIES

- External UPS (For system)
- Operator Console (Open-Closed/Adjustable/I-stand)
- 21,5"- 27" Flat Monitor
- Input / Output Rollers
- Test Kit (STP/ASTM)
- Protective Cover
- Search Table
- Tray Return System (Motorized/Gravity)
- Inclined Conveyor
- Ultrasonic Rat Repellent
- Radiation Meter

## STANDARD IMAGE PROCESSING FEATURES

- Perfect View (Detail Enhancement) (PV)
- Edge Enhancement (EE)
- Pseudo Color (PS)
- Organic Materials (OM)
- Inorganic Materials (IM)
- Black & White (B/W)
- Inverse Colors (IN)
- High Penetration (HP)
- Variable Edge Enhancement (+E -E)
- Variable Density (+D -D)
- Variable Gamma (+G -G)
- Variable Color Separation (+C -C)
- Zoom (64x)
- Sniper Zoom
- Recall Previous Images
- Manual/Automatic Archive
- Annotated Archive
- Multi Energy Viewer (4 - 6 Color)
- Atomic Number Display (Z Value)

## STANDARD FEATURES

- Programmable Function Keys
- Parcel Counter
- Date and Time Display
- Virtual Threat Image Projection (TIP)
- Organic/Inorganic Threat Alarm
- Operator Training Program (OTP)
- UPS (For Computer Supply)
- Multi Languages
- Self Diagnosis
- Generator Timer
- Bi-Directional Scanning
- Automatic Stop Conveyor
- Emergency Stop Buttons

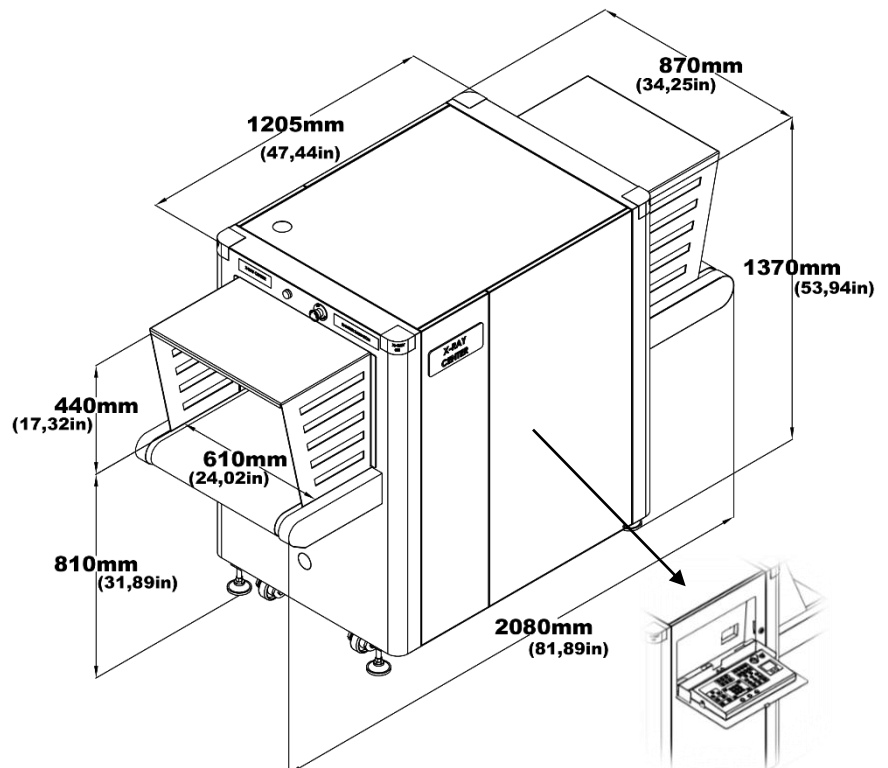

The keyboard can be produced optionally as integrated into the device.

<sup>1</sup>As tested on X-Ray Center Ltd. test piece. Conveyor speed is 0.20 m/sec.

Due to continuous product development, X-Ray Center reserves the right to change specifications without notice.

